



NASX

Tandem, Spread & Triple

STANDARD FEATURES

- 7.5'w Dual NXP Ramp Door Sled Trailer, A-frame
- 3500# Dexter Torsion Axles
- Self Adjusting Electric Brakes, EZ Lube Hubs
- NXP Stainless Steel Camshaft Latch System
- ProFlap™, Revolutionary Ramp Door Flap
- Aluminum Grab Handles
- Flush Lock Curbside Door - 32"W x 70"H
- Integrated Triple Tube Tongue - 2 5/16" coupler
- 1 Piece Seamless Aluminum Roof
- Bonded Exterior Skin - .030 Aluminum
- A-frame, drop Leg, zinc coated tongue jack
- 24" ATP stone guard
- Marine Deck Plywood Floor - 3/4"
- 3/4" Marine Deck Liner - 12"
- 16" O/C Walls and Floor(Triple)
- 24" O/C Walls and Floor(Tandem/Spread)
- 16" O/C Aluminum Tube Roof Bows
- LED Interior/Exterior Lights
- 2 - 12v Dome Lights
- 15" Silver Mod Wheels, 205 75 R15 Tires
- GVRW: 7000# Tandem/Spread, 9990# Triple

PRICE AND SPECIFICATIONS SUBJECT TO CHANGE WITHOUT NOTICE
OPTIONS ADDED TO BASE UNITS DECREASE PAYLOAD CAPACITY

NASX-5



For Additional Specs & Photos, go to:
neomfg.com

e-mail: sales@neomfg.com

21900 US 12 Sturgis, MI 49091
269.503.7630

DISTANCE BETWEEN WHEEL WELLS IS 82"

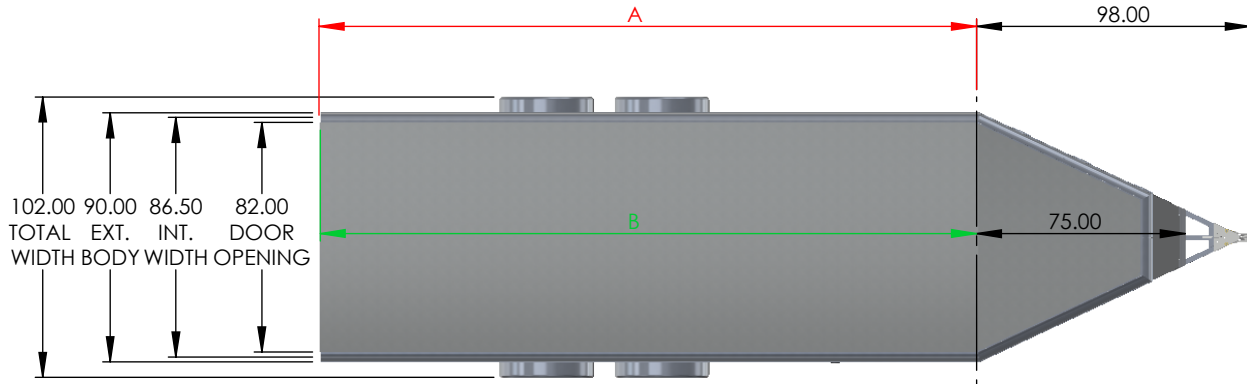

Model		Outside Box Length (A)	Inside Box Length (B)
NASX1975TR	TANDEM AXLE	168"	166"
NASX2175TR		192"	190"
NASX2375TR		216"	214"
NASX2575TR	TANDEM	240"	238"
NASX2775TR	SPREAD	264"	262"
NASX2975TR	AXLE	288"	286"
NASX3075TR	TRIPLE AXLE	300"	298"
NASX3275TR		324"	322"
NASX3475TR		348"	346"

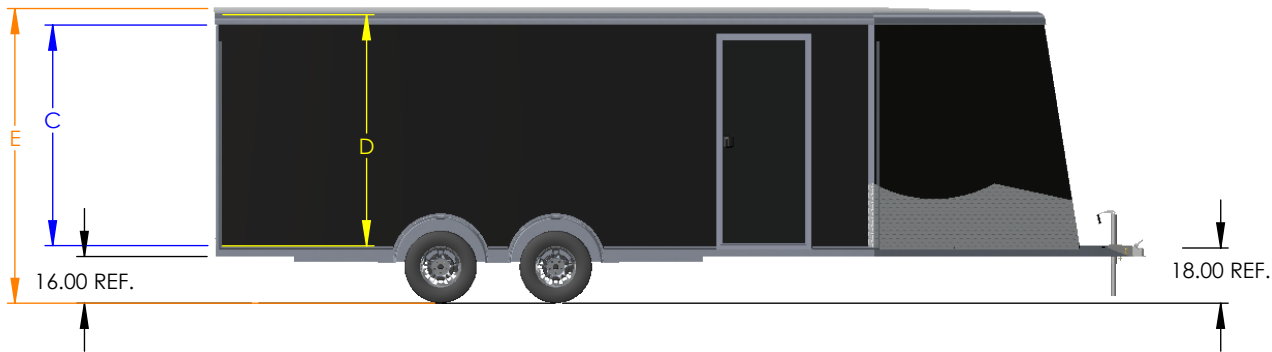

NASX7.5 Round Top	Rear Door Hgt (C)	Front Door Hgt	Front Door Width	Int Hgt @ Center (D)	Overall Hgt (E)
STD Height	73.25"	69.25"	74.00"	78.50"	99.25"
6" Plus Height	79.25"	75.25"	74.00"	84.50"	105.25"
12" Plus Height	85.25"	81.25"	74.00"	90.50"	111.25"



DRAWN BY: TYLER A BOURASSA
DATE: 6/11/2019

TRAILER MODEL:	NASX
TITLE:	TRAILER MEASUREMENTS
DO NOT SCALE DRAWING	